

6.5 ton
8.5 ton

max
54 cm

max
50 cm

System
LEADER



ALPINO

MODEL	ALPINO					
Splitting force	6.5 ton			8.5 ton		
Adjustable cutter stroke	50 cm			50 cm		
Min. - Max. splitting diameter	5 - 40 cm			5 - 50 cm		
Hydraulic oil tank	6 lt			6 lt		
Lateral log support extensions (EN 609-1:2017)	■			■		
Fall arrest guards (EN 609-1:2017)	■			■		
Controls as standard (Exclusive THOR system)						
ITEM No.	65.100	65.101	85.100	85.101	85.102	85.103
Power supply EL = electric, HVP = tractor, VS = petrol	EL 230 Volt	EL 400 Volt	EL 230 Volt	EL 400 Volt	VS 3200 rpm	HVP 540 rpm
Power required (HP / kW)	2.5 / 1.85	2.5 / 1.85	2.5 / 1.85	4 / 3	5 / 3.8	15 / 11
Working pressure (bar) <i>DP= double pump</i>	230	230	250 / DP	250	250	250
1 st cutting speed (cm/sec)	3.2	3.2	10	5.3	4.5	7,5
2 nd cutting speed (cm/sec)	---	---	1.8	---	---	---
Return speed (cm/sec)	15.2	15.2	12.3	36	30	36
Rear controls coverage	□	□	■	■	■	■
Full wheels (Ø mm)	200	200	250	250	250	250
Working dimensions (<i>W x L / H = 156 cm</i>)	116 x 70	116 x 70	116 x 70	116 x 70	116 x 100	116 x 100
Weight (kg)	106	106	112	115	118	122
Price						

■ = Included as standard // □ = Not available

Shipping Dimensions / Weights: pages 36-37

OPTIONAL ACCESSORIES		
Description	Lifting hook	60° cutter
Item No.	845.201	800.087.K
Price		

A targeted choice for every family!



ALPINO»

Cutter inclined at 6° for reducing split effort

Fall arrest guards INCLUDED

Ergonomically-positioned and comfortable dual-control levers for splitting phase

Extensions on both sides, INCLUDED.

Curved board for the logs for greater splitting performance

Very solid frame structure

Carter for controls coverage for 8.5 tons as standard

Hydraulic oil tank incorporated in the frame

200 mm dia. full wheels, standard on 6.5 ton model

250 mm dia. full wheels, standard on 8.5 ton model

Approved pedal (standard) for approach stroke and log centering

L

W

expedition DATA

DIMENSIONS & WEIGHTS

Shipping dimensions (overall dimensions in cm) // Pallet Weight

ALPINO



EL + HVP version

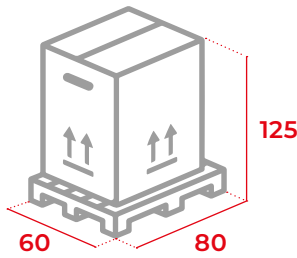

Pallet Weight: 7 kg

VS version

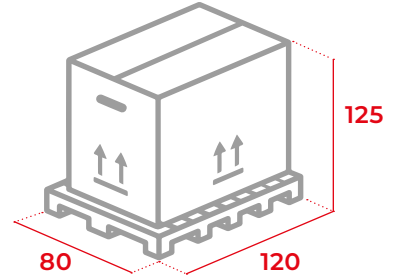

Pallet Weight: 25 kg

MIGNON



EL version + HVP

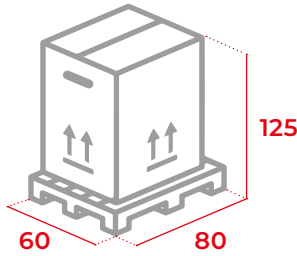

Pallet Weight: 7 kg

VS version + KOMBI

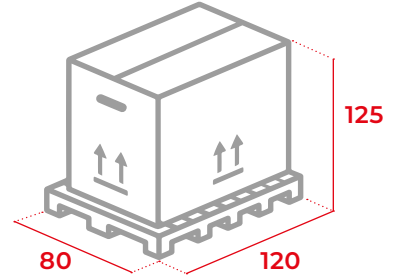

Pallet Weight: 25 kg

FARMER

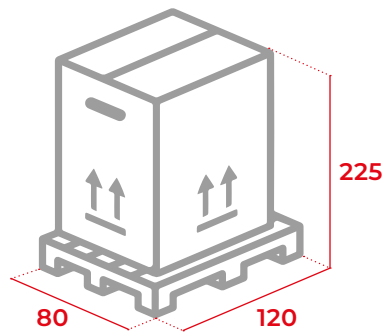

Pallet Weight: 25 kg

FARMER
DIAVOLIK

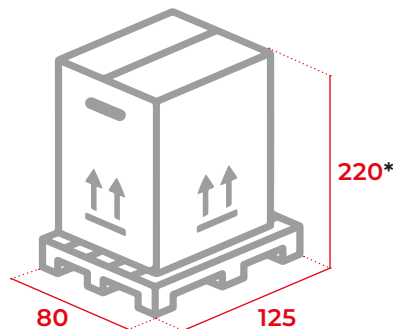

Pallet Weight: 25 kg

*(With optional winch mounted: H = 230 cm)