

Hydraulic vertical log splitters

MAGIK MULTIUSE

FARMER/MAGIK MULTIUSE



Hydraulic cylinder with a unique position for transport and for work

Two ergonomically positioned levers activate the splitting phase

Sensor for blocking the hydraulic flow

Rear lights bar for road traffic in rest position

Single control for log centering
(Exclusive THOR system)



Interchangeable self-lubricating Teflon guides

Special steel cutter with inclined cut for greater penetration and less effort



Aluminium cutter stroke adjustment easily adjustable to the desired height

Very wide base for ergonomic support of the log to be split

»»» Foldable at the end of work thanks to the rotatable support foot to minimize the machine size

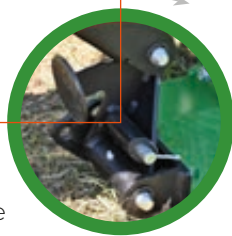

FARMER > 13 ton
MAGIK > 18 ton
16 ton



H max
• 104 cm
• 115 cm



min > max
5 > 90 cm





Standard Controls

System LEADER



FARMER MAGIK MULTIUSE

MODEL	FARMER MULTIUSE		MAGIK MULTIUSE	
Splitting height / Cutter stroke	104 / 94 cm		115 / 105 cm (adjustable)	
Controls	Standard		System LEADER	
Splitting force	13 ton	18 ton	16 ton	
ITEM No.	37.M.111	39.M.121	36.M.120	36.M.121
Power supply: VS = petrol / EL = electric	VS 3200 rpm	VS 3200 rpm	VS 3200 rpm	EL 400 Volt
Power required (HP / kW)	9 / 6.7	13 / 9.55	9 / 6.7	5.5 / 4
Working pressure (bar) DP = double pump	260 / DP	280 / DP	250 / DP	250
Hydraulic oil tank	18 lt	19 lt	23 lt	23 lt
1 st cutting speed (cm/sec)	8	6	6	4.5
2 nd cutting speed (cm/sec)	25	14	14	10.5
Return speed (cm/sec)	11.5	11	11	8.5
Rotation speed in rpm	3200	3200	3200	1400
Side hoist (EN 609-1:2017)	■	■	■	■
Rear lights bar	■	■	■	■
Mud guards	■	■	■	■
Towing hook	■	■	■	■
Public road homologation	*	*	*	*
Working dimensions (L x W x H) cm	290 x 122 x 263		290 x 122 x 268	
Weight (kg)	464	494	558	558
Price				
OPTIONAL ACCESSORIES				
Description	Lifting hook	Digital hour meter	Spare wheel	
Item No.	845.201	400.113.K	845.157.K	
All models	*	*	*	
Price				

Shipping Dimensions / Weights: pages 36-37 ■ = Included as standard // * = Optional

Hydraulic vertical log splitters

Trailed and approved for public roads

NB: Public road homologation on demand



Towing hook approved for Ø 50 ball.
Stabilizer wheel

Pneumatic wheels (4.50.10.C)

Plastic Mudguards

Lights bar for road traffic



Anti-rollover stabilizing feet

Spare wheel (OPTIONAL)



Tipping from transport to work position



expedition DATA

DIMENSIONS & WEIGHTS

Shipping dimensions (overall dimensions in cm) // Pallet Weight

ALPINO



EL + HVP version

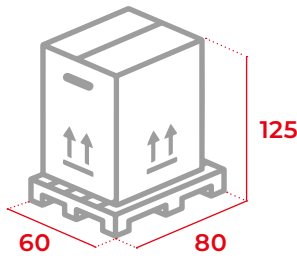

Pallet Weight: 7 kg

VS version

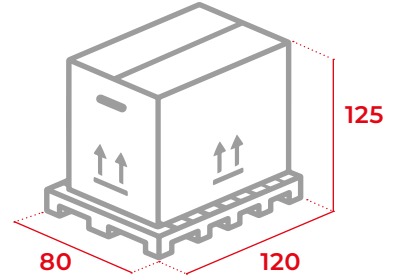

Pallet Weight: 25 kg

MIGNON



EL version + HVP

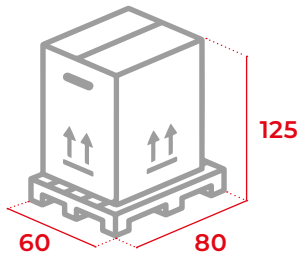

Pallet Weight: 7 kg

VS version + KOMBI

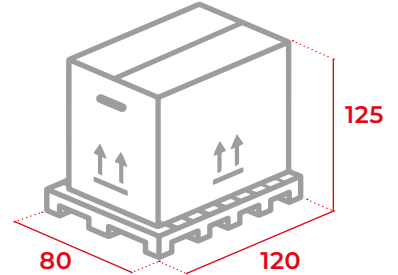

Pallet Weight: 25 kg

FARMER

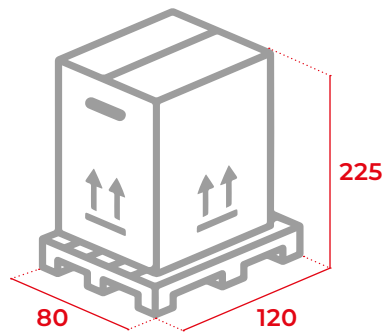

Pallet Weight: 25 kg

FARMER
DIAVOLIK

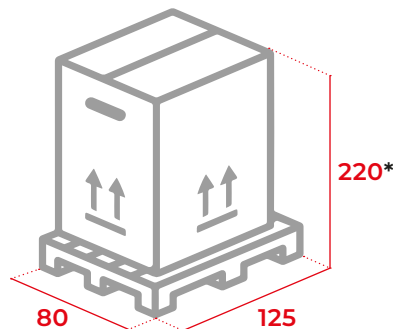

Pallet Weight: 25 kg

*(With optional winch mounted: H = 230 cm)

Hydraulic LOG SPLITTERS

Shipping dimensions (overall dimensions in cm) // Pallet Weight

MAGIK >>



Only **VS** version (Petrol)
Mod. 18 ton

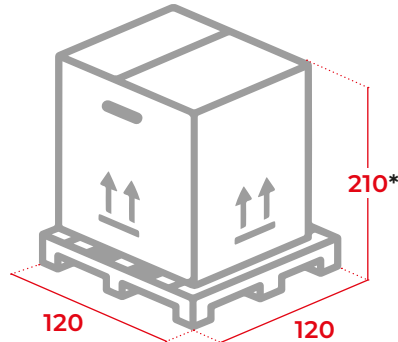

All other versions
Mod. 13 / 18 / 20 ton

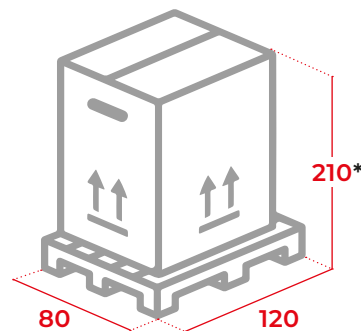

Pallet Weight:
25 kg

*(With optional winch mounted:
H = 218 cm)

DIAVOLIK STOP >>
and GO!

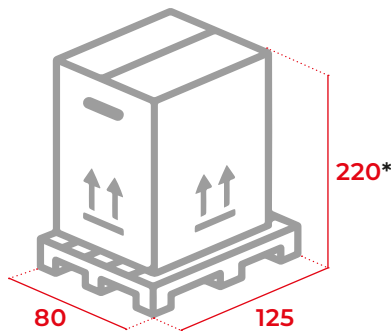

Pallet Weight:
25 kg

*(With optional winch mounted:
H = 230 cm)

FARMER MULTISE >>

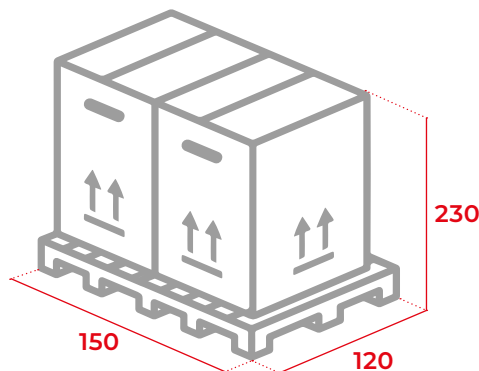

Pallet Weight:
25 kg

MAGIK MULTISE >>

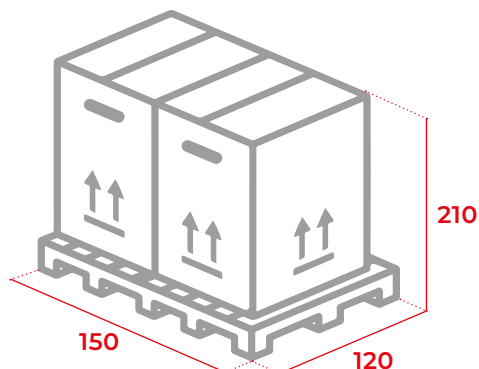

Pallet Weight:
25 kg