

9 ton
11 ton

max
54 cm

max
60 cm

System
LEADER



MIGNON

ECO //
PROF

MODEL	MIGNON ECO			MIGNON PROF				
Splitting force	9 ton			11 ton				
Adjustable cutter stroke	50 cm			50 cm				
Min. - Max. splitting diameter	5 - 50 cm			5 - 60 cm				
Lateral log support extensions <i>(EN 609-1:2017)</i>	■			■				
Fall arrest guards <i>(EN 609-1:2017)</i>	■			■				
Hydraulic oil tank	8.75 lt	9 lt		9 lt				
Controls as standard <i>(Exclusive THOR system)</i>								
ITEM No.	23.100	23.101	23.102	23.110	23.111	23.112	23.113	23.115
Power supply EL = electric, HVP = tractor, VS = petrol	EL 230 Volt	EL 400 Volt	VS 3200 rpm	EL 230 Volt	EL 400 Volt	VS 3200 rpm	HVP 540 rpm	Kombi EL 400V+HVP
Power required (HP / kW)	3 / 2.2	4 / 3	7 / 5	3 / 2.2	5.5 / 4	9 / 6.7	17 / 12.5	5.5 / 4 - 17 / 12.5
Working pressure (bar) <i>DP = double pump</i>	250	250	250	240 / DP	240	230	240	250
1 st cutting speed (cm/sec)	4	5.3	4.8	7.9	7.2	4.7	6	7.2 - 10
2 nd cutting speed (cm/sec)	---	---	---	1.4	---	---	---	---
Return speed (cm/sec)	25	36	32	8.6	16	12.5	16	16 - 16
Full wheels (Ø mm)	300 ■	300 ■	300 ■	300 ■	300 ■	*	200 ■	200 ■
Pneumatic wheels (Ø mm)	*	*	*	*	*	400 ■	□	□
Working dimensions <i>(W x L / H = 156 cm)</i>	125 x 80	125 x 80	125 x 90	125 x 80	125 x 80	125 x 100	125 x 75	125 x 86
Weight (kg)	153	153	160	158	158	181	155	179
Price								

■ = Included as standard □ = Not available * = Optional

Shipping Dimensions / Weights: pages 36-37

OPTIONAL ACCESSORIES				
Description	Lifting hook	60° cutter	Pneumatic wheels	Side hoist
Item No.	845.201	800.113.K	810.025.K	810.039.K
Price				

Hydraulic vertical log splitters

Powerful, safe and persistent! A choice of quality and prestige.



MIGNON > ECO // PROF



Fall arrest guards INCLUDED

Ergonomically-positioned and comfortable dual-control levers for splitting phase

Extensions on both sides, INCLUDED

Curved board for the logs for greater splitting performance

Wheels of big dimensions as standard on some models (see technical data sheet)

Approved pedal (standard) for approach stroke and log centering

OPTIONAL
Newly designed side lift to bring the log for splitting on the work table (Exclusive THOR system)
-
Item No. 810.039.K
-
This accessory can also be mounted on previous versions

L

W



expedition DATA

DIMENSIONS & WEIGHTS

Shipping dimensions (overall dimensions in cm) // Pallet Weight

ALPINO



EL + HVP version

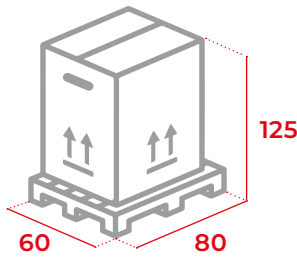

Pallet Weight: 7 kg

VS version

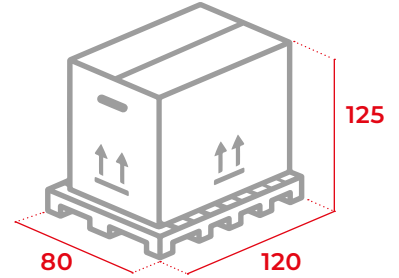

Pallet Weight: 25 kg

MIGNON



EL version + HVP

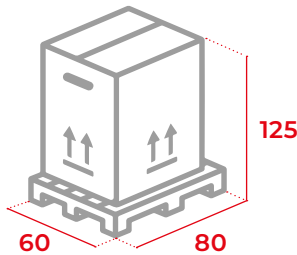

Pallet Weight: 7 kg

VS version + KOMBI

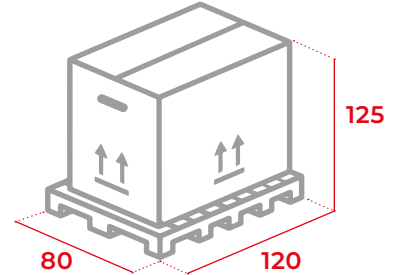

Pallet Weight: 25 kg

FARMER

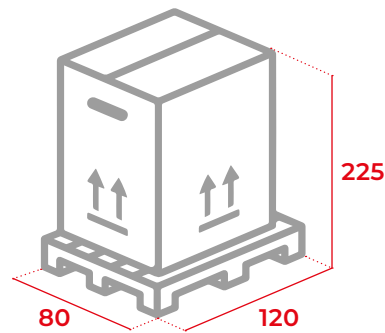

Pallet Weight: 25 kg

FARMER
DIAVOLIK

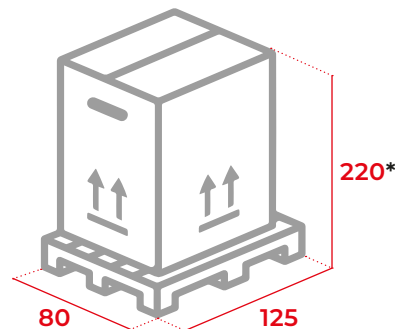

Pallet Weight: 25 kg

*(With optional winch mounted: H = 230 cm)