

25 ton
30 ton

max
123 cm

max
100 cm

STOP
andGO!

DIAVOLIK

STOP
and
GO!







MODEL	DIAVOLIK STOPandGO!			
Splitting height / Cutter stroke	123 cm / 113 cm			
Hydraulic oil tank	38 lt (Internal tank)	85 lt (External tank)		
Splitting force	25 ton	30 ton		
ITEM No.	46.100	46.101	46.102	46.103
Power supply EL = electric, V.PF = tractor, Kombi = EL + V.PF	V.PF 540 rpm max.	V.PF 540 rpm max.	EL 400 Volt	Kombi EL 400V + V.PF
Power required (HP / kW)	46 / 34	50 / 37	7.5 / 5.5	7.5 / 5.5 - 50 / 37
Working pressure (bar) <i>DP = double pump</i>	260	315	315 / DP	315 (DP x EL)
1 st cutting speed (cm/sec)	8	8	8	8 / 8
2 nd cutting speed (cm/sec)	16.8	16.8	17.4	17.4 / 16.8
Return speed (cm/sec)	14.6	14.6	15.1	15.1 / 14.6
Rotation speed in rpm	450	450	1400	1400 / 450
3-point connector 1 st - 2 nd cat.	■	■	■	■
Wheels (Ø mm)	□	□	□	□
Working dimensions (W x L / H = 316 cm)	110 x 140	110 x 140	110 x 140	110 x 140
Weight (kg)	630	678	688	715
Price				

■ = Included as standard // □ = Not available

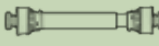
Shipping Dimensions / Weights: pages 36-37

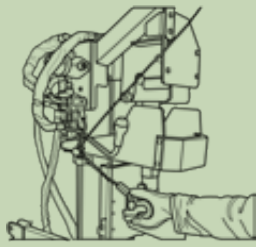
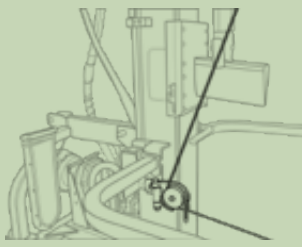
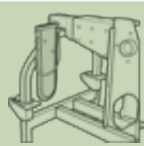
OPTIONAL ACCESSORIES (For descriptions and technical data see pages 28-29)

				
Lifting hook	Cardan shaft	Timber tong		
			Winch Pulling force: 400 kg	Pulley to pull from the bottom
Chainsaw holder	Board 50 cm with pedal, extension and container			

Splitter with high sturdiness and stability for industrial and agricultural use!



OPTIONAL

Manual or remote controlled winch. They can drag logs from a distance of 20 meters.

12 Volt electric controls unique and with exclusive **STOPandGO!** system



Side hoist included (EN 609-1:2017) mounted on the left side of the machine with dual function for fall arrest protection. Foldable at the end of work



Hydraulic cylinder retractable for storage. H = 215 cm



Electric control for the return stroke of the cutter

Safety sensor and lever protector

Tempered and high strength steel cutter, with a length of 30 cm and 6° inclined cut for a greater penetration and less effort

Interchangeable, bolted GS400 cast iron cutter guides

OPTIONAL

Lifting hook







Double side protection, with lifting hook support integrated, mounted on the right side of the machine for both long and short logs (EN 609-1:2017) Foldable at the end of work

DIAVOLIK STOPandGO! >>

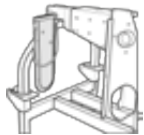

TOPLINE *family* // > OPTIONAL

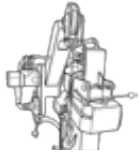
DO YOU NEED A CUSTOMIZED CONFIGURATION...?

MAGIK	Item No.	Tractor	Electric Petrol	Kombi	PRICE
 Lifting hook	845.201	*	*	*	
 60° cutter (13 ton)	845.056.K	*	*	*	
 Cardan shaft	600.059	*	□	* V.PF	
 Chainsaw holder	845.202.K	*	□	*	
 Transport trolley	845.084.K	*	□	*	
 Board 50 cm with pedal, extension and container	845.250.K	*	*	*	
 Manual winch	845.184.K (13/18 ton)	*	□	*	
	845.190.K (20 ton)	*	□	* V.PF	
 Timber tong	845.204	*	□	* V.PF	
 Pulley to pull from the bottom	845.205.K	*	□	* V.PF	

* = Optional // □ = Not available









SPLITTING HEIGHT WITH BOARD 50 CM

Board 50 cm with lateral extension, **pedal control for the centering phase** and container to lift the logs on the split base.

ACCESSORIES

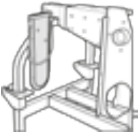

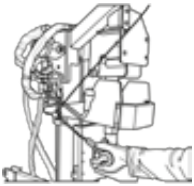
CHOOSE BETWEEN OPTIONAL ACCESSORIES!

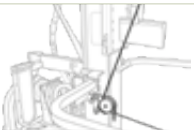
DIAVOLIK <small>STOP and GO!</small>	Item No.	Tractor	Electric	Kombi	PRICE
 Lifting hook	845.201	*	*	*	
 Cardan shaft	600.059	*	□	* V.PF	
 Chainsaw holder	845.202.K	*	□	*	
 Board 50 cm with pedal, extension and container	891.056K	*	*	*	
 Manual winch	891.021.K	*	□	* V.PF	
 Radio controlled winch	891.018.K	*	□	* V.PF	
 Timber tong	845.204	*	□	* V.PF	
 Pulley to pull from the bottom	845.205.K	*	□	* V.PF	

* = Optional // □ = Not available



The innovative **“NOT REVERSE Winch”** exclusive THOR system allows the drum to stop automatically when the cable is completely unwound or when it is completely rewound, without operating errors.

TECHNICAL DETAILS

- Hydraulic power supply from an existing plant.
- Manual control valve with automatic cable outlet.
- Cable with hook included. Terminal equipped with safety lock.
- 180° rotating pulley included.

Attention:
this winch can also be mounted on the log splitters of our previous versions or on log splitters not manufactured by us.

Attention:
the winch can be mounted on Kombi models only if the machine is connected to the tractor's 3-point hitch!



Manual or remote controlled winch.

expedition DATA

DIMENSIONS & WEIGHTS

Shipping dimensions (overall dimensions in cm) // Pallet Weight

ALPINO



EL + HVP version

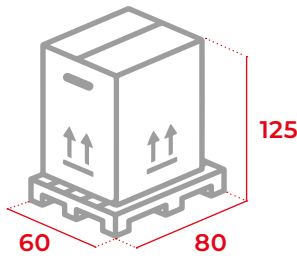

Pallet Weight: 7 kg

VS version

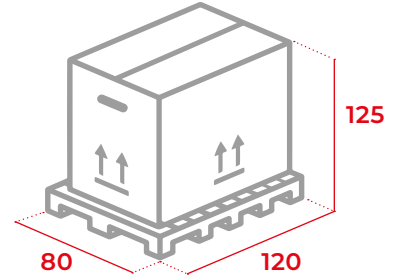

Pallet Weight: 25 kg

MIGNON



EL version + HVP

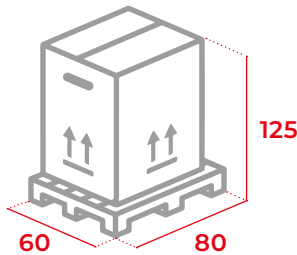

Pallet Weight: 7 kg

VS version + KOMBI

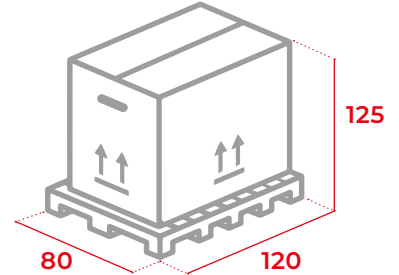

Pallet Weight: 25 kg

FARMER

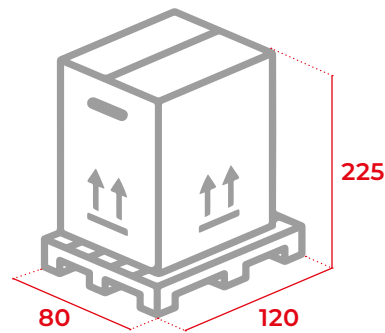

Pallet Weight: 25 kg

FARMER
DIAVOLIK

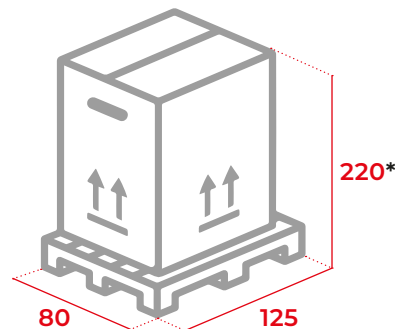

Pallet Weight: 25 kg

*(With optional winch mounted: H = 230 cm)

Hydraulic LOG SPLITTERS

Shipping dimensions (overall dimensions in cm) // Pallet Weight

MAGIK >>



Only **VS** version (Petrol)

Mod. 18 ton

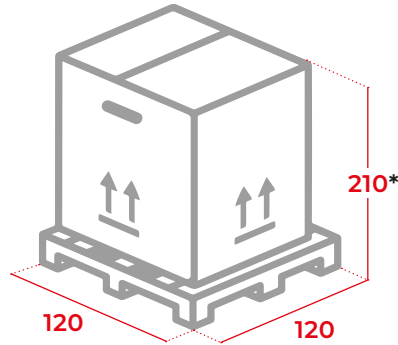

All other versions

Mod. 13 / 18 / 20 ton

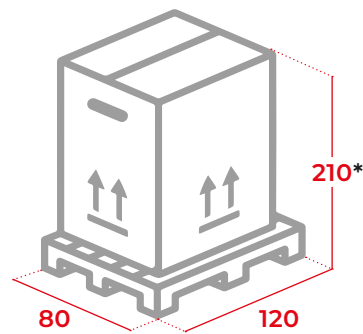

Pallet Weight:
25 kg

*(With optional winch mounted:
H = 218 cm)

DIAVOLIK STOP >>
and GO!

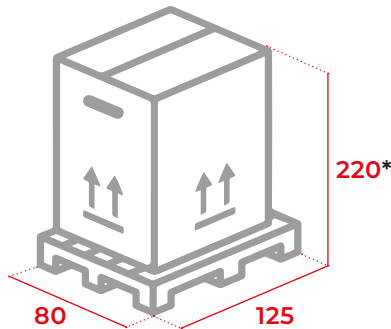

Pallet Weight:
25 kg

*(With optional winch mounted:
H = 230 cm)

FARMER MULTISE >>

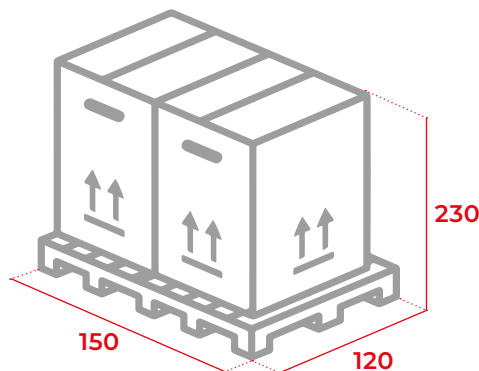

Pallet Weight:
25 kg

MAGIK MULTISE >>

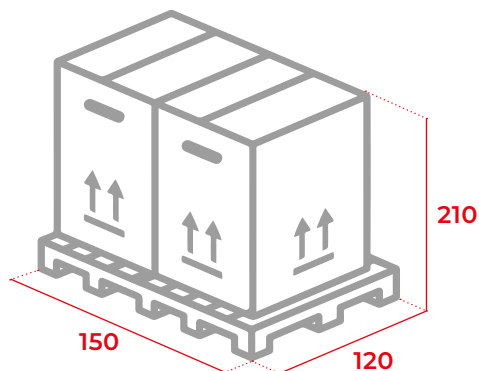

Pallet Weight:
25 kg