

max  
Ø 30 cm

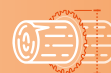

Ø 750 mm  
(90 teeth)





# KATANA 750

MODEL	KATANA 750			
Max. cutting diameter	Ø 30 cm			
Widia blade 30 mm dia. hole <u>included</u>	Ø 750 mm			
Blade revs (rpm)	1400			
ITEM No.	K75.101	K75.103	K75.104	K75.105
Alimentation: <b>EL</b> = electric (S6), <b>V.PF</b> = tractor, <b>Kombi</b> , <b>VS</b> = gasoline	<b>V.PF</b> 540 rpm	<b>EL</b> 400 Volt	<b>Kombi</b> (EL 400 V + V.PF)	<b>VS</b> 3200 rpm
Power required (HP / kW)	25 / 18	12 / 9	7.5 / 5.5 - 25 / 18	13 / 9.55
Blade stop brake	■	■	■	■
3-point connector 1 <sup>st</sup> - 2 <sup>nd</sup> cat.	■	■	■	---
Cut adjuster and discharge conveyor for conveyor belt	■	■	■	■
Side foldable logs feed	■	■	■	■
Full wheels (Ø mm)	400	400	400	400
Working dimensions (W x L x H cm)	170 x 170 x 120			170 x 215 x 120
Weight (kg)	257	325	300	350
<b>Price</b>				

■ = Included as standard // □ = Not available // \* = Optional

Shipping Dimensions / Weights: page 46

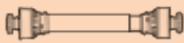
OPTIONAL ACCESSORIES				
Description	Steel blade	Thrust roller	Pneumatic wheels Ø 400	Cardan shaft with safety bolt
Item No.	DA.750.30	D.60.120	200.193.K	600.125
<b>Electric</b>	*	*	*	□
<b>Tractor</b>	*	*	*	*
<b>Kombi</b>	*	*	*	* (V.PF)
<b>Gasoline</b>	*	*	*	□
<b>Price</b>				

# Great stability for industrial and agricultural use!



KATANA » 750

Emergency braking device for models with PTO  
*(Exclusive THOR system)*

Switch with release coil, brake and thermal protection

Safety cover of the cutting area  
*(Exclusive THOR system)*

Lever for unlocking the bench movement  
*(Exclusive THOR system)*

**OPTIONAL:** Thrust roller

Handle height adjustment for the action of the bench

Self-lubricating bushings mounted on the fulcrum of the swing tank

Side feed mounted on bearings, with vertical stop position for transport

Transmission with low friction XPA belts (3 belts)

**OPTIONAL:** Cardan shaft with safety bolt

3-point connector 1<sup>st</sup> - 2<sup>nd</sup> cat. as standard on all models

Cut adjuster and discharge conveyor as standard (already pre-set for conveyor belt).

Full transport wheels mm 400 dia. as standard  
**OPTIONAL:** pneumatic wheels mm 400 dia.

# SAW BENCHES

Shipping dimensions (overall dimensions in cm) // Pallet Weight

KATANA »700



**EL / V.PF** versions

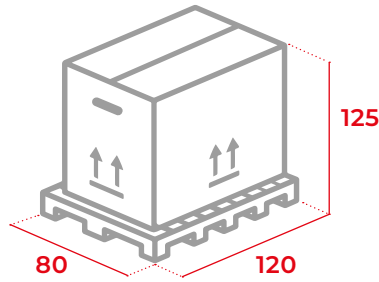

Pallet Weight: 25 kg

**VS** version

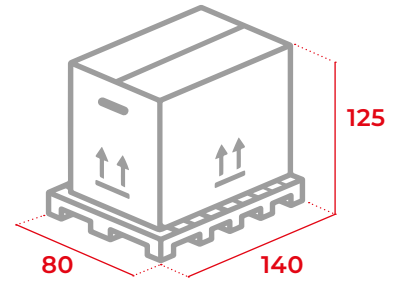

Pallet Weight: 25 kg

KATANA »750



**V.PF / EL / KOMBI** versions

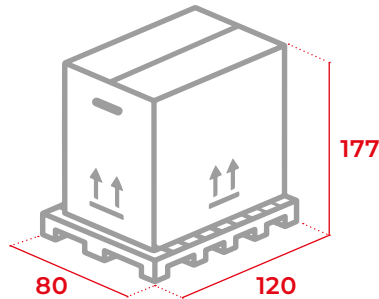

Pallet Weight: 25 kg

**VS** version

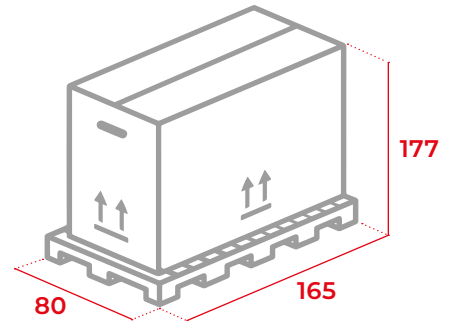

Pallet Weight: 25 kg

TANDEM »

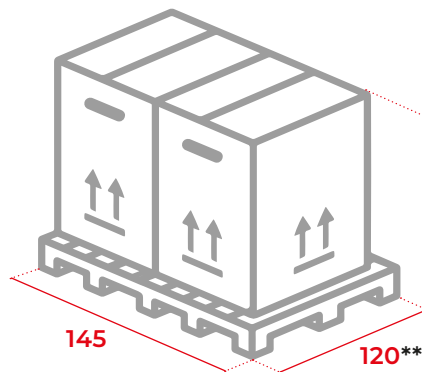

**Pallet Weight:**  
25 kg

**\*V.PF version - Cod. 76.III:**

- Saw benches height = 215 cm
- Belt dimensions = 340 x 70 x 70 cm

**\*\*EL version - Cod. 76.103:**

- Packaging depth = 128 cm

250\*

145

120\*\*